



Company Profile

COMPANY PROFILE

- Company Name : **ABADI SENTOSA CV.**
- SIUP : Small
- Established : 12 March 2004
- Address : Ruko Araliya HY 43/46. Harapan Indah 2, Bekasi
Jawa Barat

- Business Field
 - Supplier Laboratory & Analytical Equipment
 - Supplier Hospital Laboratory Equipment
 - Supplier Control Instrument Apparatus
 - Design Proto type Pilot Plant Machinery
 - Design Waste Water Treatment
 - Design Cold Room
 - Maintenance & Service

- Brand **BIO-AUTOTECH** : Design **IPAL & COLD ROOM**
- Mission : Provides the best solutions, by the development of technology
- Vision : Responsible after sales service in professional fully committed to principal that will give benefits all in a relationship business
- Target : Be a healthy company in the aspect of management and performance to be big and professional

- Experience Fully Automatic system
 - Design Pilot Plant Logam Tanah Jarang BATAN Yogyakarta
 - Design Pilot Plant Gadolinium Oksida BPPT – TEKMIIRA Bandung
 - Design Fermenter and Mixing Vessel
 - Pilot Plant Expert Oil cracking extraction Lemigas Cepu.
 - Maintenance & Calibration Gas Turbine Pertamina Cilamaya, Tegalgede, and Bitung.
 - Installation, Calibration Radio Room PJKA – 200 station
 - Installation, Training Laboratory Equipment at all RSU district +/- 200 RSU in Indonesia.
 - Design Immersion system for Oil Palm and Coconut Copra
 - Design Spray Dryer
 - Design Pure Water system
 - Design Hospital Waste Water Treatment / IPAL
 - RSU BANDA - Maluku Tengah
 - Puskesmas Ibh - Sumatra Barat
 - Puskesmas Lampasi - Sumatra Barat
 - Laboratorium PRAMITHA - Balikpapan
 - RSU Brebes - Jateng
 - Dinas PUPR - Tangerang
 - RS ECM - Tangerang
 - Design COLD ROOM
 - Dinas Kesehatan Provinsi Bangka Belitung
 - Kalbe Farma, Kalbe Milko, Dipa Farma Sain, Dipa Inter Sain
 - P3GL Kementerian ESDM, Yakult, RS Polri, PELNI Jakarta.

LABORATORY EQUIPMENT

01 Spectrophotometer

UV VIS Spectrophotometer
Atomic Absorption Spectrophotometer
Nano Spectrophotometer
X-Ray Fluorescence Spectrometer
X-Ray Diffractometer
Flame Photometer
Fluorescence Spectrophotometer
ICP Emission Spectrometer
FTIR/NIR



02 Chromatograph

Gas Chromatograph
Liquid Chromatograph
Autosampler
Ion Chromatograph
Gas Chromatograph Mass Spectrometer
Liquid Chromatograph Mass Spectrometer



03 Centrifuge

Intelligent Blood Bank Refrigerated Centrifuge
Digital Blood Bank Refrigerated Centrifuge
Benchtop Low-Speed Centrifuge
Benchtop High Speed Centrifuge
Beauty Centrifuge(PRP PPP PRF)
Rotor



04 Incubator & Oven

CO₂ / Anaerobic Incubator
Shaking Incubator
Climate Chamber
Heating / Biochemical Incubator
Drying Oven
Muffle Furnace
Thermostat Bath



05 Organic Element Analysis

Kjeldahl
Soxhlet
Fat Analyzer
Fiber Analyzer



06 Clinic Equipment

Sterilization
PCR
Nucleic Acid Extractor
Elisa Microplate Reader
Chemistry Analyzer
Hematology Analyzer



07 General Equipment

Viscometer
Lab Furniture
Laboratory Balance
Moisture Analyzer
Freeze Dryer
Homogenizer
Ultrasonic Clear
Stirrer/Shaker/Mixer

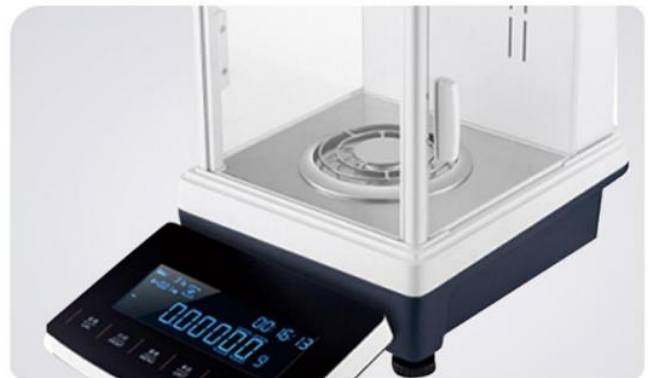

EXPERIENCE

1. COLD ROOM (BA-7070-CR)

Software / Hardware Ability

- Integrated One Control Panel Cold Room and Software
- 3 Operating Mode : Manual / Semi Auto / Fully Automatic
- Touchscreen Control Panel
- Automatically cooling unit works alternately every 3 hours
- Automatically changes if one of the systems does not work
- Graph Record Data Logging
- Software Profesional DIADEM calculation graph
- Print PDF daily/weekly/monthly/yearly
- Graphics can be remote from PC or Smartphone
- Temperature can be calibrated remotely
- Electronic Expansion control valve
- Humidity Below 80%
- Notification Sent by Email
 - High & Low Temperature Alarm limit
 - Evaporator or Condenser not working properly
 - Freon reduced / exhausted gas freon
 - High and low pressure compressor over limit setting
 - Fault Over Current Compressor
 - Over Temperature Compressor
 - Damage cooler will be notified every 3 hours



3
YEARS
★★★★★★
WARRANTY

COLD ROOM



- Vaccine Cold Room 2 - 8 °C
- Morgue Cold Room -25 - (-20) °C

QUALIFIED
AFTER SALES SERVICE

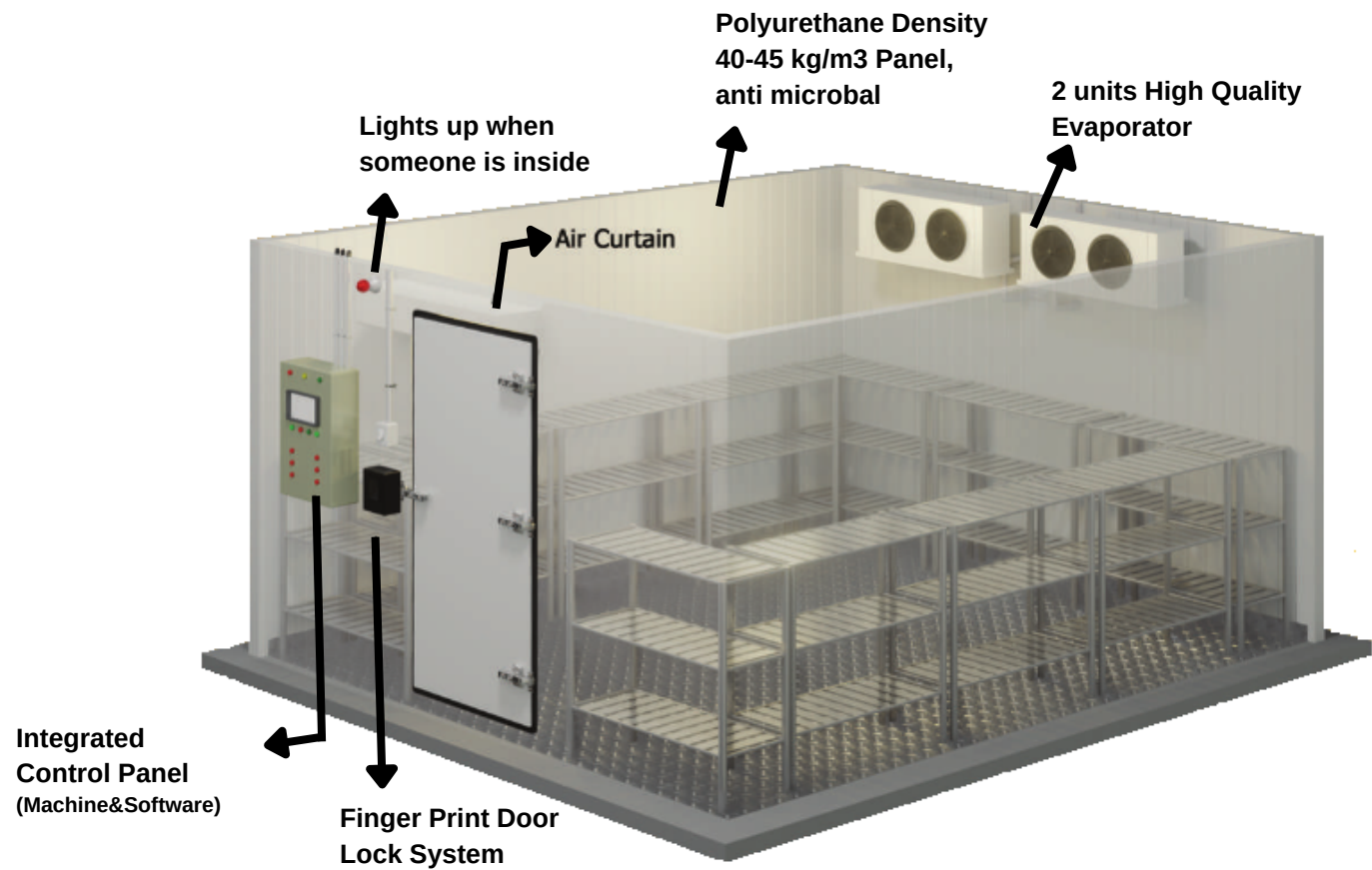



MOT FULL SET EQUIPMENTS



2. SMART TECHNOLOGY - Fully Automatic IPAL

Dengan kemajuan Technology IPAL yang semakin berkembang PT LABINDO SENTRA SAINTIFIC dengan merk **Bio- AUTOTECH** mengeluarkan product terbaru New Generation dengan nama **SMART TECHNOLOGY – One Touch Service** dengan kemampuan fully automatic sbb :

- Automatic pH yang terdapat pada bak REAKTOR akan stabil antara pH 6.0 – 8.0
- Automatic Sludge Cleaning pada Reaktor menyebabkan output reactor akan selalu bersih
- Automatic Back Wash Cleaning Bio Membrane (warranty 2 tahun)
- Automatic Bio Membrane RUN/STOP under control by COD controller
- Output Bio Membrane dijamin BOD < 30 mg/L, COD < 100 mg/L dan TSS <10 mg/L
- DO monitor untuk meyakinkan bahwa Air Aerobe power blower bekerja baik
- Control Flow untuk memastikan bahwa pompa re sirkulasi bekerja baik
- Adjustable Automatic Chlorine Flow Controller
- Optional software under control by PC dan Android HP
- Dengan penambahan RO water treatment Output Bio membrane dapat dipergunakan kembali sebagai sumber mata air pengganti PDAM

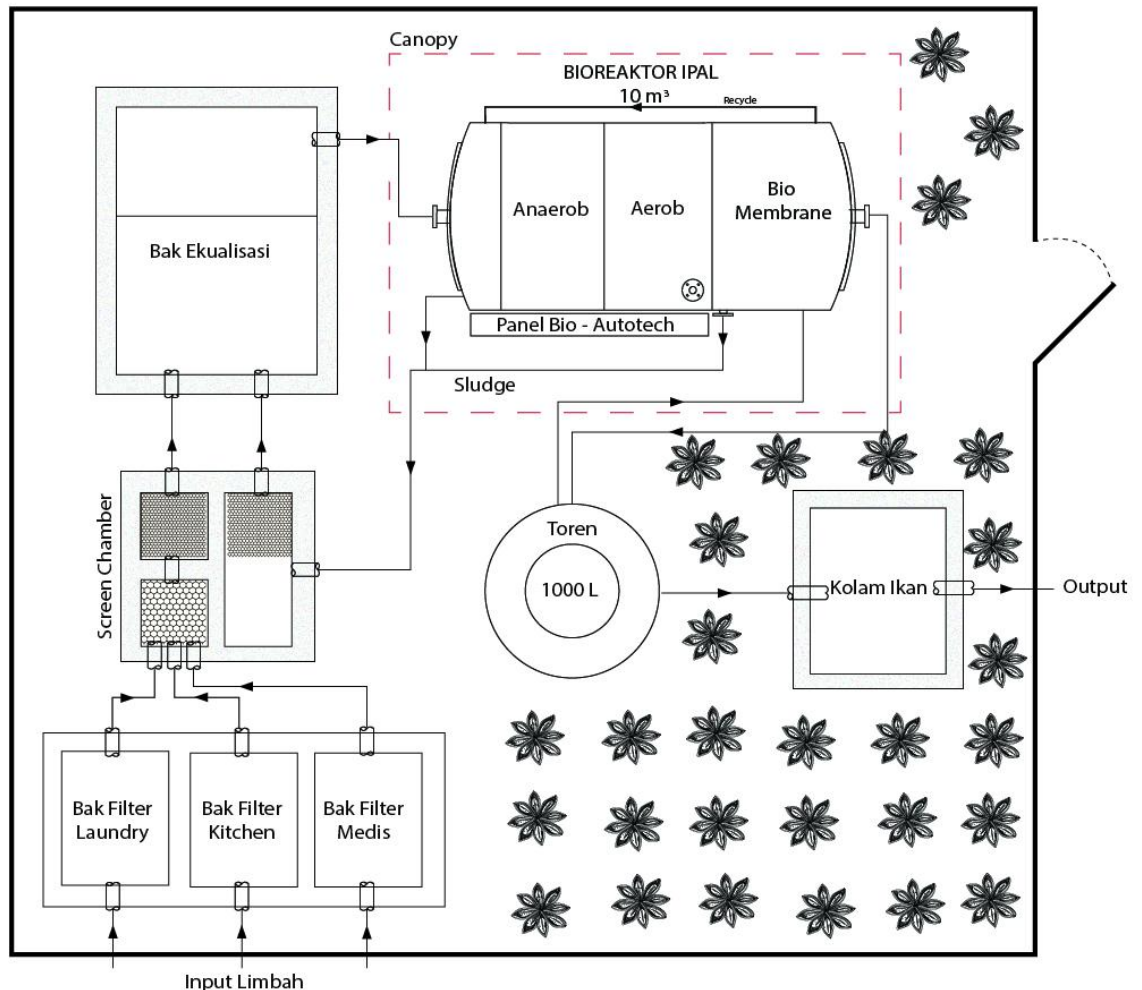

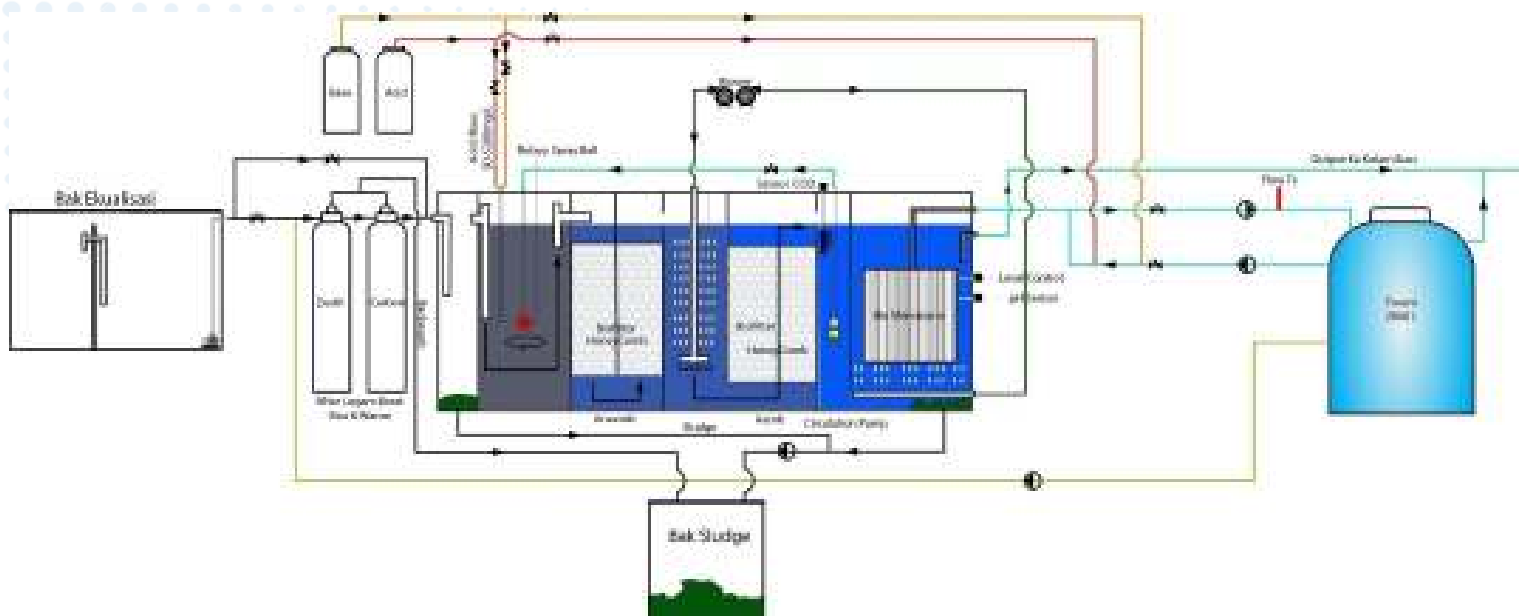

IPAL Puskesmas LAMPASI - SUMBAR



3. PILOT PLANT PROJECT

- Pilot Plant Gadolinium Oksida BPPT-TEKMIRA Bandung , with 14 Reactor. Fully Automatic Processed with National Instrument Software



Proses Flow Diagram Proses design GD Oksida

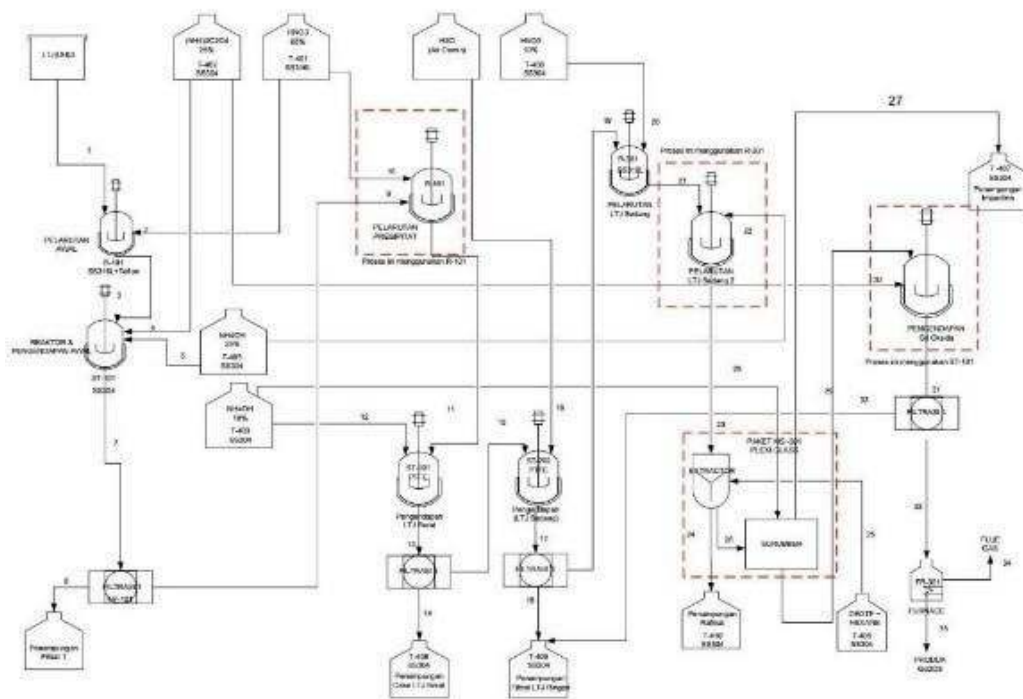

- Pilot Plant product development with 10 Reactor – BATAN Yogyakarta



4. Wastewater Treatment (IPAL)



5. Mixing Vessel / Fermenter, Fully Automatic Programmable - Biofarma Bandung
One Touch Service from Cleaning - Sterilization 121,01 degC - Media In



CT SIMULATOR / LASER POSITIONING SYSTEM (MOVING LASER)

RD Laser Positioning System (Moving Laser)

RD/DJG4

RD Laser Positioning System (Moving Laser) is a device for patient accurate positioning in precise radiotherapy. It adopts digital control and consists of movement laser tracks and a control computer, with characteristics such as accurate positioning and easy operation.

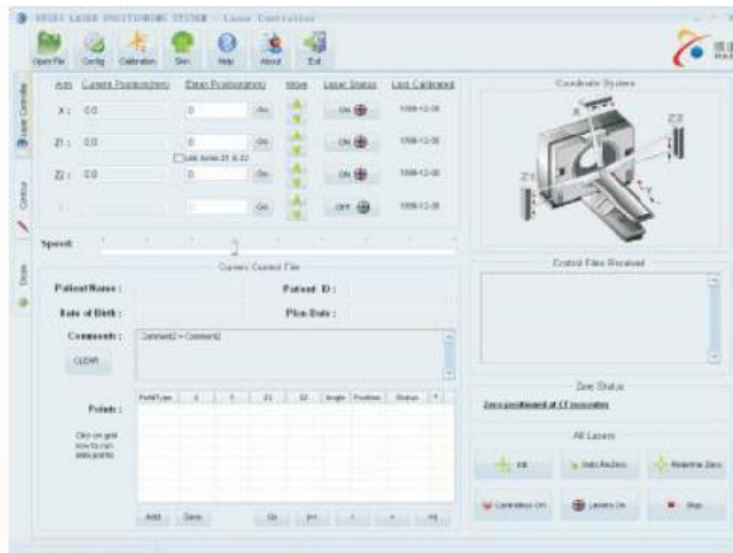

Moving Laser control software

Features:

- Friendly interface, easy operation and use;
- Connected with all kinds of treatment planning systems (TPSs) with DICOM 3.0/RT;
- Ensures accurate laser positioning with exactitude linear guide rails and linear coding closed-loop feedback control;
- Selection of computer WIFI control or manual control box control facilitates direct control laser beams in CT room;
- Capable of being installed in the CT room or analog positioning machine room with diversity installation methods to protect interior decoration as much as possible;
- Combination: an axis, three-axis, five-axis methods.

Specification:

- Positioning accuracy: $\pm 0.2\text{mm}$
- Laser beam moving range: $-300\text{mm} \sim 300\text{mm}$
- Color: red
- Laser Class: II
- Line width: $<1\text{mm}$ (3-5m wide)



WIFI control box



Manual control box



8. Online Monitoring (ONLIMO)

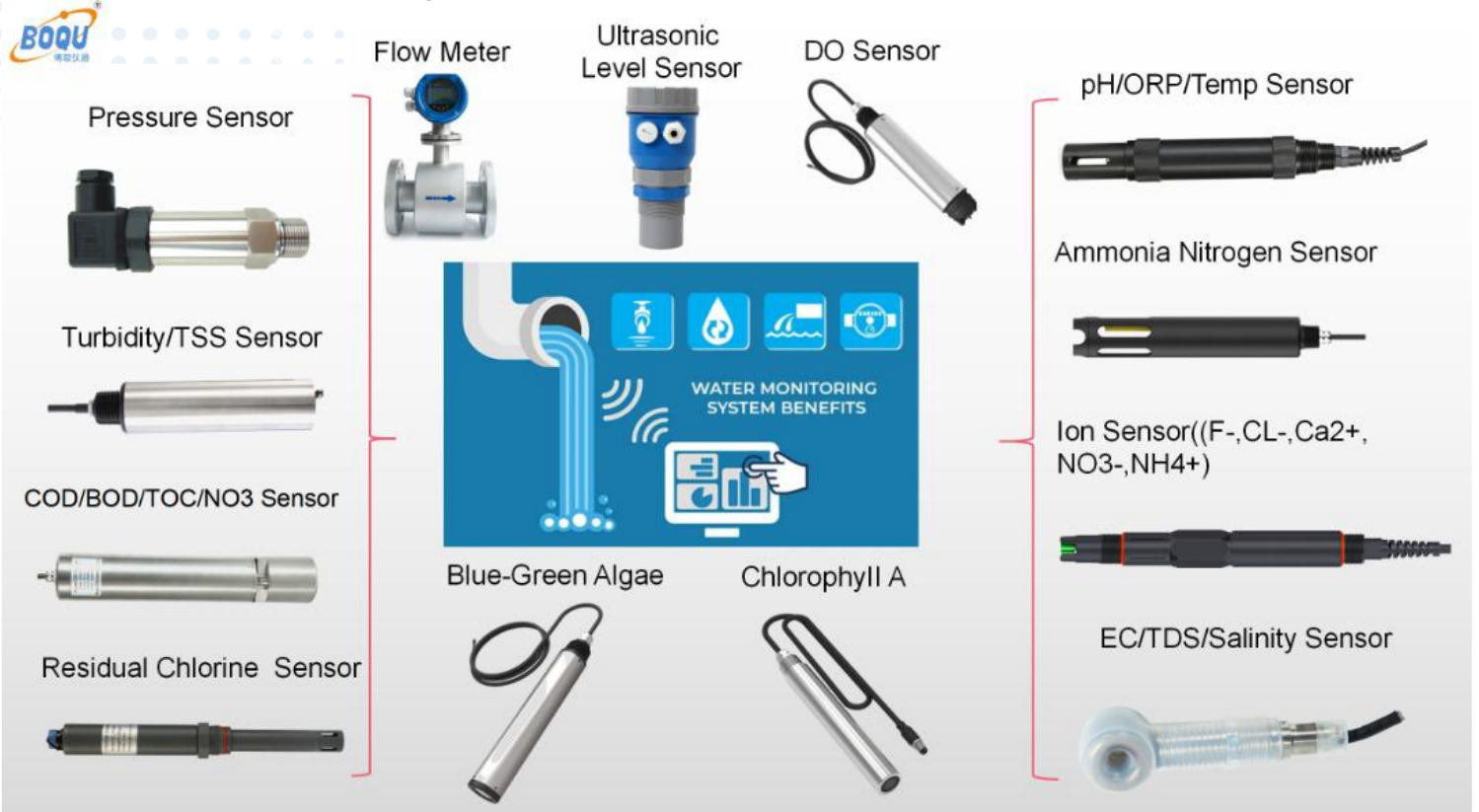

9. Distributor / Sole Agent , Laboratory Equipment and Instrument measurement

1. COAL Gasifier - HENAN
2. Blower – SUMO
3. Genset / Dummy Load – Power City
4. High temp. Tube Furnace - ELITE
5. Syngas / Flue gas Analyzer - WUHAN
6. TAR Analyzer
7. Particulate Analyzer
8. Gas Engine
9. Oil Free Screw Air Compressor
10. Sulfur Analyzer - CKIC
11. C/H/N Element Analyzer
12. Proximate Analyzer
13. Trace Elements Analyzer
14. Real Time PCR
15. XFR Analyzer
16. GC /GCMS/ AAS
17. HPLC / LCMS / Spectrophotometer
18. TOC Analyzer
19. Infrared Sulphur Determination
20. Bomb Calorimeter
21. Ash Fusion determination
22. Plastometric Indices tester
23. Hardgrove Grindability Index tester
24. Crusher / Grinder / Sample Divider
25. Riffle divider / Sieving shaker
26. Boiler Feed Water
27. Online recycle WWT & Water treatment.

10. Exclusive Distributor

INCENERATOR

The IS-M70 is one of the most advanced incinerators in its range. The hop loading design means loads are well contained within the system during the process. The IS-M70 is perfect for small clinics, dental practices or small hospital facilities where incineration is a daily job.

COLD STORAGE CHILLER

Model	Capacity	Temperature Range	Key Features
IS-1000	1000L	-10°C to -20°C	Fully programmable, remote control, alarm, auto defrost, energy saving, low noise, compact design, easy maintenance, built-in safety features.
IS-2000	2000L	-10°C to -20°C	Full auto control, remote control, alarm, auto defrost, energy saving, low noise, compact design, easy maintenance, built-in safety features.
IS-3000	3000L	-10°C to -20°C	Full auto control, remote control, alarm, auto defrost, energy saving, low noise, compact design, easy maintenance, built-in safety features.

REAL TIME PCR

Real-time PCR machine for clinical and research use.

DNA RNA SPECTROPHOTOMETER

OPTIZEN Series
UV-Vis, Microvolume Spectrophotometer

Elisa Reader BERTHOLD



BIOBASE BK-96A Fluorescence Quantitative Pcr Detection System Thermal Cycler



Fully Automated Human Blood Biochemistry Chemistry Analyzer Fully Automatic BK-600



Auto Hematology Analyzer BK-3100



Gas Chromatography-Mass Spectrometer



Gas Chromatograph BK-GC901



Microwave Digester BMD-3



Graphite Digester BGD-420F



Strong Acid & Alkali Storage Cabinet



Intermediate Frequency Therapy Instrument BK-MF-IIA



Medicine Cabinet



Jacketed Glass Reactor



Vacuum Atmosphere Furnace MXV6-10TP



-40C Freezer BDF-40V58 BDF-40V368



BIOBASE BK-3000 Automatic Cryostat Microtome



-25C Freezer 305L



BIOBASE SCSJ-V-45 SCSJ-V-63 Lab Ro Machine Water Purifier System



Constant Temperature and Humidity Incubator (BJPX-HTBII)



STERILIZER AUTOCLAVE

MQS1.0 PULSE VACUUM STERILIZER

Technical Specification



REFRIGERATED CIRCULATOR BATH



HUMIDITY TEST CHAMBER

THR-8000-D Walk In Temperature Humidity Test Chamber

Machine Appearance



DEEP FREEZER -60 to -90 degC



SHAKING WATER BATH / WATER DISTILLATION



LEMARI ASAM / FUME HOOD



LAMINAR AIR FLOW



MULTY INPUT WATER ANALYZER

Ph, DO, Conductivity, Turbidity, Salinity, COD, Chlorine



ULTRA PURE WATER PURIFIER



FERMENTOR



KRUSS MICROSCOPE



11. BIOBASE

BIOLOGICAL SAFETY CABINET



FREEZER



VERTICAL LAMINAR FLOW CABINET



AUTOCLAVE



AUTO CHEMISTRY ANALYZER



CO2 INCUBATOR



FUME HOOD



CENTRIFUGE



AUTOMATED SAMPLE PROCESSING SYSTEM



NUCLEIC ACID EXTRACTION SYSTEM

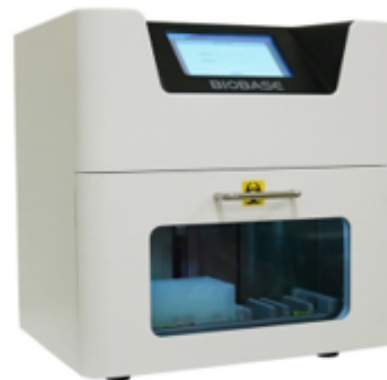

AUTOMATIC CHEMILUMINESCENCE IMMUNOASSAY SYSTEM





We can also supply another brand corresponding user request and we will take full responsibility for the warranty, after sales service and repairs with International standards.

We able and willing to repair and modify all instruments of all brands in your office premises

All our design will attached of Design Qualification (DQ) , Performance Qualification (PQ) , Installation Qualification (IQ) , Operation Qualification (OQ) , Maintenance Qualification (MQ) .

We are responsible for all the products that we supply includes installation, training, and After Sales Service.

Best Regards,



Priswanto Budi Kuncoro
 Direktur
 62 81281577000